

REQUEST FOR QUOTATION
(RFQ_036_2011)

To: Companies/Firms	DATE of issue: 05 October 2011
	REFERENCE: RFQ_036_2011 Supply and installation of the office furniture for MBA Project

Dear Sir / Madam:

- Your firm is invited to submit a quotation for supply and installation of the office furniture for MBA Project administered by UNDP Lao PDR.
- To enable you to submit a Quotation please find enclosed:

Annex I: Requirements and Specifications
 Annex II: UNDP General Terms and Conditions for Purchase orders
 Annex III: Vendor registration form

Full set of bidding documents can be downloaded from our web-site at:
<http://www.undplao.org/vacancies/procurementnotice.php> or

- Your quotation shall be submitted in sealed envelope or electronically, duly signed and stamped on or **before close of business 14 October 2011** to the following address:

Address: UNDP Lao PDR
 Lane Xang Avenue
 Ban Hatsady-Tai
 P.O. Box 345
 Vientiane, Lao PDR
 Tel. 856 21 267777

Attention: UNDP Procurement/Logistics Unit

In order to speed up the process of submission the Quotations can be also submitted electronically to our secure e-mail box: lao.procurement@undp.org before the indicated deadline.

- ATTENTION:** Please mark your envelop as follows: **Company Name, contact details, "RFQ/036/2011" Supply and installation of office furniture for MBA Project**".
- Electronic quotations shall be marked in the subject as follows: "RFQ/036/2011"**.

UNDP will not be responsible for postal delays, if any, in the delivery of the bid documents or non-receipt of the same. **Late proposals will be rejected.**

- Quotations submitted by the bidders shall comprise the following documents:**
 - Price schedule inclusive of all costs, including labor, delivery and installation
 - Company's profile/vendor registration form as per Annex III.
 - Catalogues of the offered furniture.

5. Request for additional information:

If you request additional information please send e-mail to Phadthakone.sophavilay@undp.org or diver.rasulov@undp.org for any inquiries.

GENERAL CONDITIONS	
Place of Delivery	Furniture shall be delivered and installed in the project office within Vientiane Capital (address to be provided later).
Delivery period:	Delivery and installation period shall not exceed one month
Currency of the proposal	Companies should quote in USD, Lao KIP or Thai BAHT . Quotations submitted in another currency will be rejected.





TAX EXEMPTION	All quotations submitted to UNDP shall be without VAT and other direct taxes. Section 7 of the Convention on the Privileges and Immunities of the United Nations provides, inter alia, that the United Nations, including its subsidiary organs, is exempt from all direct taxes, except charges for utilities services, and is exempt from customs duties and charges of a similar nature in respect of articles imported or exported for its official use.	
Payment Terms	Payment will be made through Bank Transfer within 30 days upon receipt of invoices and certification of satisfactory completion of services by UNDP. Payment to local firms will be made in local currency only.	
Validity of Quotation	Quotation must be valid during 60 DAYS. No changes allowed during this period after submission of the quotations.	
Conversion to single currency	For conversion into single currency for the evaluation purposes the applicable UN exchange rate will be used on the last date of submission of the proposals.	
Completeness of the proposal.	Company shall submit all requested documents.	
Goods and evaluation criteria	The Evaluation Committee will examine the proposals to determine whether they are complete, whether the documents have been properly signed and whether the offer complies with the technical requirements. In case of discrepancy in unit price and total price the unit price shall prevail. The contract will be awarded to the company offered lowest technically responsive offer.	
General Terms and Conditions	See enclosed Annex IV - UNDP General Terms and Conditions	
Mode of Transport	AIR	SEA
	SURFACE	OTHERS
REQUIREMENTS		
Language: All documentation, including installation and operating manuals shall be in:		
<input checked="" type="checkbox"/> English <input type="checkbox"/> French <input type="checkbox"/> Spanish <input type="checkbox"/> Others		



NAME, FUNCTIONAL TITLE: Diyer Rasulov, UNDP Procurement Specialist
Signature:  DATE: 05.10.2011
E-MAIL ADDRESS: diyer.rasulov@undp.org

Pease visit our web-site to see other procurement and vacancy announcements
www.undplao.org

**Annex I
General Requirements and Specifications**

REFERENCE: RFQ_036_2011

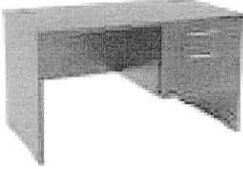
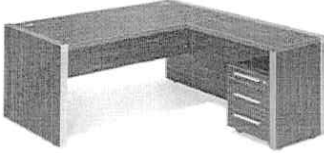
#	Description/Technical Requirements/Specification	Required quantity	
<p>Fulfilling of the below mentioned terms is obligatory for all positions: Furniture assembly and delivery in Vientiane Capital is mandatory. Address to be provided; Proposed quality and design of the product must meet the following requirements:</p> <ol style="list-style-type: none"> 1) All sizes must be written in cm in next order: length * width (or depth)* height; deflection from ordered sizes (+-10 cm) is admitted but, linking elements and proposed furniture must be of demanded size and matched to each other; 2) Top covers of the tables/cabinets/book cases must be plates in the thickness of 25 mm (admission of other size +/- 5 mm) and must be made of laminate; 3) All faceplates without exception must be protected by antistrike polyvinylchloride trim; 4) The given sizes for the furniture have tolerance +/- 10 cm. 			
Width/Depth/Height in cm			
1.	Swivel chairs with arm rest and higher back, leather cover		8
2.	Chair with armrest and higher back, fabric cover		8
3.	Conference table for 12-14 people with flexible arrangements including the following set: 4 four square tables with size 150/60/75 cm and plus two connecting sides half-circle shape with size Ø150x75 without chairs (See sample picture on the side).		1
4.	Filing Cabinet (Steel) with four shelves and ten compartments in one row/shelve for files. The cabinet should be on rollers.	 <p>S-666 ชั้นเก็บแฟ้ม 40 ช่อง <small>W:92 x D:31.1 x H:180.5 cm</small> 92/40/182</p>	2
5.	Lockable shelves/cabinets with four shelves inside (two shelves for each section) laminate.	 <p>88/40.6/182</p>	1

6.	Office Desk with lockable drawer on one side with two compartments as per attached picture. As per attached picture.	 160/70/75	6
7.	Office desk "Executive type"	 DT-8814A 88 H 1600W x 1700D x 760H 170/80/75 or 180/85/75	2
8.	Shelf (Wood), "Mai dou" (Lao made) 120wx40.6Dx182H or equal	 88/40.6/182	1

Annex II
UNDP General Terms and Conditions for Purchase orders

1. ACCEPTANCE OF THE PURCHASE ORDER

This Purchase Order may only be accepted by the Supplier's signing and returning an acknowledgement copy of it or by timely delivery of the goods in accordance with the terms of this Purchase Order, as herein specified. Acceptance of this Purchase Order shall effect a contract between the Parties under which the rights and obligations of the Parties shall be governed solely by the terms and conditions of this Purchase Order, including these General Conditions. No additional or inconsistent provisions proposed by the Supplier shall bind UNDP unless agreed to in writing by a duly authorized official of UNDP.

2. PAYMENT

2.1.1 UNDP shall, on fulfilment of the Delivery Terms, unless otherwise provided in this Purchase Order, make payment within 30 days of receipt of the Supplier's invoice for the goods and copies of the shipping documents specified in this Purchase Order.

- 2.1.2 Payment against the invoice referred to above will reflect any discount shown under the payment terms of this Purchase Order, provided payment is made within the period required by such payment terms.
- 2.1.3 Unless authorized by UNDP, the Supplier shall submit one invoice in respect of this Purchase Order, and such invoice must indicate the Purchase Order's identification number.
- 2.1.4 The prices shown in this Purchase Order may not be increased except by express written agreement of UNDP.

3. TAX EXEMPTION

3.1 Section 7 of the Convention on the Privileges and Immunities of the United Nations provides, inter alia, that the United Nations, including its subsidiary organs, is exempt from all direct taxes, except charges for utilities services, and is exempt from customs duties and charges of a similar nature in respect of articles imported or exported for its official use. In the event any governmental authority refuses to recognize UNDP's exemption from such taxes, duties or charges, the Supplier shall immediately consult with UNDP to determine a mutually acceptable procedure.

3.2 Accordingly, the Supplier authorizes UNDP to deduct from the Supplier's invoice any amount representing such taxes, duties or charges, unless the Supplier has consulted with UNDP before the payment thereof and UNDP has, in each instance, specifically authorized the Supplier to pay such taxes, duties or charges under protest. In that event, the Supplier shall provide UNDP with written evidence that payment of such taxes, duties or charges has been made and appropriately authorized.

4. RISK OF LOSS

Risk of loss, damage to or destruction of the goods shall be governed in accordance with DDU Incoterms 2000, unless otherwise agreed upon by the Parties on the front side of this Purchase Order.

5. EXPORT LICENCES

Notwithstanding any INCOTERM 2000 used in this Purchase Order, the Supplier shall obtain any export licences required for the goods.

6. FITNESS OF GOODS/PACKAGING

The Supplier warrants that the goods, including packaging, conform to the specifications for the goods ordered under this Purchase Order and are fit for the purposes for which such goods are ordinarily used and for purposes expressly made known to the Supplier by UNDP, and are free from defects in workmanship and materials. The Supplier also warrants that the goods are contained or packaged adequately to protect the goods.

7. INSPECTION

1. UNDP shall have a reasonable time after delivery of the goods to inspect them and to reject and refuse acceptance of goods not conforming to this Purchase Order; payment for goods pursuant to this Purchase Order shall not be deemed an acceptance of the goods.

2. Inspection prior to shipment does not relieve the Supplier from any of its contractual obligations.

8. INTELLECTUAL PROPERTY INFRINGEMENT

The Supplier warrants that the use or supply by UNDP of the goods sold under this Purchase Order does not infringe any patent, design, trade-name or trade-mark. In addition, the Supplier shall, pursuant to this warranty, indemnify, defend and hold UNDP and the United Nations harmless from any actions or claims brought against UNDP or the United Nations pertaining to the alleged infringement of a patent, design, trade-name or trade-mark arising in connection with the goods sold under this Purchase Order.

9. RIGHTS OF UNDP

In case of failure by the Supplier to fulfil its obligations under the terms and conditions of this Purchase Order, including but not limited to failure to obtain necessary export licences, or to make delivery of all or part of the goods by the agreed delivery date or dates, UNDP may, after giving the Supplier reasonable notice to perform and without prejudice to any other rights or remedies, exercise one or more of the following rights:

- a) Procure all or part of the goods from other sources, in which event UNDP may hold the Supplier responsible for any excess cost occasioned thereby.
- b) Refuse to accept delivery of all or part of the goods.
- c) Cancel this Purchase Order without any liability for termination charges or any other liability of any kind of UNDP.

10. LATE DELIVERY

Without limiting any other rights or obligations of the parties hereunder, if the Supplier will be unable to deliver the goods by the delivery date(s) stipulated in this Purchase Order, the Supplier shall (i) immediately consult with UNDP to determine the most expeditious means for delivering the goods and (ii) use an expedited means of delivery, at the Supplier's cost (unless the delay is due to Force Majeure), if reasonably so requested by UNDP.

11. ASSIGNMENT AND INSOLVENCY

- 11.1. The Supplier shall not, except after obtaining the written consent of UNDP, assign, transfer, pledge or make other disposition of this Purchase Order, or any part thereof, or any of the Supplier's rights or obligations under this Purchase Order.
- 11.2. Should the Supplier become insolvent or should control of the Supplier change by virtue of insolvency, UNDP may, without prejudice to any other rights or remedies, immediately terminate this Purchase Order by giving the Supplier written notice of termination.

12. USE OF UNDP OR UNITED NATIONS NAME OR EMBLEM

The Supplier shall not use the name, emblem or official seal of UNDP or the United Nations for any purpose.

13. PROHIBITION ON ADVERTISING

The Supplier shall not advertise or otherwise make public that it is furnishing goods or services to UNDP without specific permission of UNDP in each instance.

14. CHILD LABOUR

The Supplier represents and warrants that neither it nor any of its affiliates is engaged in any practice inconsistent with the rights set forth in the Convention on the Rights of the Child, including Article 32 thereof, which, inter alia, requires that a child shall be protected from performing any work that is likely to be hazardous or to interfere with the child's education, or to be harmful to the child's health or physical, mental, spiritual, moral or social development.

Any breach of this representation and warranty shall entitle UNDP to terminate this Purchase Order immediately upon notice to the Supplier, without any liability for termination charges or any other liability of any kind of UNDP.

15. MINES

The Supplier represents and warrants that neither it nor any of its affiliates is actively and directly engaged in patent activities, development, assembly, production, trade or manufacture of mines or in such activities in respect of components primarily utilized in the manufacture of Mines. The term "Mines" means those devices defined in Article 2, Paragraphs 1, 4 and 5 of Protocol II annexed to the Convention on Prohibitions and Restrictions on the Use of Certain Conventional Weapons Which May Be Deemed to Be Excessively Injurious or to Have Indiscriminate Effects of 1980.

Any breach of this representation and warranty shall entitle UNDP to terminate this Purchase Order immediately upon notice to the Supplier, without any liability for termination charges or any other liability of any kind of UNDP.

16. SETTLEMENT OF DISPUTES

16.1 Amicable Settlement

The Parties shall use their best efforts to settle amicably any dispute, controversy or claim arising out of, or relating to this Purchase Order or the breach, termination or invalidity thereof. Where the Parties wish to seek such an amicable settlement through conciliation, the conciliation shall take place in accordance with the UNCITRAL Conciliation Rules then obtaining, or according to such other procedure as may be agreed between the Parties.

16.2 Arbitration

Unless, any such dispute, controversy or claim between the Parties arising out of or relating to this Purchase Order or the breach, termination or invalidity thereof is settled amicably under the preceding paragraph of this Section within sixty (60) days after receipt by one Party of the other Party's request for such amicable settlement, such dispute, controversy or claim shall be referred by either Party to arbitration in accordance with the UNCITRAL Arbitration Rules then obtaining, including its provisions on applicable law. The arbitral tribunal shall have no authority to award punitive damages. The Parties shall be bound by any arbitration award rendered as a result of such arbitration as the final adjudication of any such controversy, claim or dispute.

17. PRIVILEGES AND IMMUNITIES

Nothing in or related to these General Terms and Conditions or this Purchase Order shall be deemed a waiver of any of the privileges and immunities of the United Nations, including its subsidiary organs.